

DTL DPN124 2.6 TJGN Control Specification Guideline  
Division 16520

PART 1. GENERAL

1.1 INTRODUCTION

- A. The intent of this specification is to provide for furnishing, installing, testing and placing into operation, a Part Night locking type photocontrol for outdoor luminaire.

1.2 DESCRIPTION OF WORK

- A. Provide a partial locking type (also known as a TwistLock®) photocontrol for outdoor lighting
- B. Requirements are indicated elsewhere in these specifications.
- C. Follow the following wiring diagram:

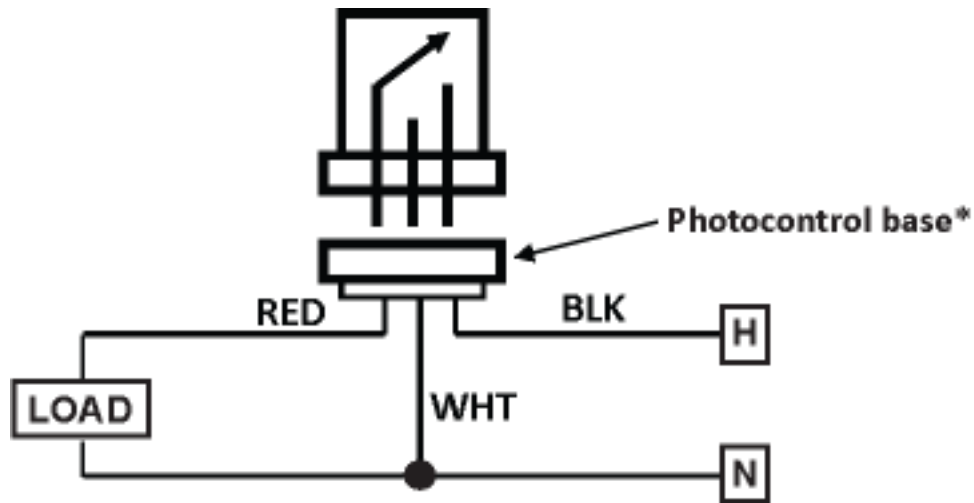

1.3 QUALITY ASSURANCE

- A. Independent Testing Laboratory - The controls shall be tested and listed under the UL 773.
- B. Manufacturer experience - To insure a uniform installation and single responsibility, all switching equipment described herein shall be supplied by a manufacturer with a minimum of 10 years experience in lighting control systems.
- C. Manufacturer shall be:

Dark To Light  
3825 Columbus Rd. SW  
Granville, Oh. 43023  
800-442-6745  
www.darktolight.com

- D. Manufacturing Location shall be ISO certified.
- E. Product shall be DTL (Dark To Light) **DPN124 2.6 TJGN**. Alternate products meeting prior approval requirements may be proposed as add or deduct alternate only.

1.4 CODES AND STANDARDS

- A. UL 773
- B. ANSI C136.10
- C. ANSI C136.24

- D. ANSI C136.2-2004
- E. IEEE C62.41.2-2002
- F. IES DG-13

## 1.5 SUBMITTALS

Prior to fabrication manufacture shall submit the following materials for approval.

- A. Manufacturer's published catalog data sheets for all equipment and components of the photocontrols.
- B. Shop Drawings - Submit detailed drawings and documentation of photocontrols. As a minimum, the shop drawings shall include the following:
  - 1. Schematic diagrams
  - 2. Full catalog sheets

## PART 2. PRODUCTS

### 2.1 SYSTEM DESCRIPTION

- A. The photocontrol shall control the luminaire on which it is installed.
- B. The photocontrol shall be a locking type photocontrol as per ANSI C136.10

### 2.2 RATINGS

- A. Photocontrol shall have a rated line voltage of 120-277 Volts AC at 50/60 Hertz
- B. Photocontrol shall have a load rating of at least 1000 VA ballast
- C. Photocontrol shall operate all HID, halogen, incandescent, LED, solid state, fluorescent, and relay loads
- D. Photocontrol shall consume 0.8 Watts or less at 120 Volts AC
- E. Photocontrol shall turn ON in  $2.6 \pm 0.6$  foot candles
- F. Photocontrol shall turn OFF in the middle of the night according to the following rules:
  - 1. The first night of usage the photocontrol shall keep all lights on from dusk to dawn
  - 2. The photocontrol shall calculate and store the duration of each night as measured from dusk to dawn regardless of the state of any lights during those nights
  - 3. After the first night of usage the photocontrol shall turn lights ON at dusk and turn them OFF in the middle of the night as determined by calculating half of the time between dusk and dawn on the previous night
  - 4. The photocontrol shall contain volatile memory and reset to its first night state after any power outage
  - 5. The photocontrol shall not support clock-based turn off (instructions to turn the lights off at a specific time of the night)
  - 6. The photocontrol shall not guarantee precise measurements of night time during adverse weather conditions such as fog or rain
- G. Photocontrol shall fail ON as per definitions in ANSI C136.10
- H. Photocontrol shall turn ON instantly
- I. Photocontrol shall have a 2-5 second delay before turning OFF
- J. Photocontrol shall operate in -40 degrees to 158 degrees Fahrenheit (-40 degrees to 70 degrees Celsius) ambient temperatures
- K. Photocontrol shall withstand an Interface Temperature of 105 degrees Celsius where Interface Temperature is defined in ANSI C136.10

### 2.3 HARDWARE

- A. Housing and Window
  - 1. The housing shall be 2 inches (50.8 millimeters) high and 3 inches (76.2 millimeters) in diameter
  - 2. The photocontrol shall weigh 2.6 ounces (74 grams)
  - 3. Housing of photoelectric control shall be green polypropylene
  - 4. Housing shall be made of an impact and UV resistant material.

- a.) Photocontrol shall have an impact resistance of greater than 1.0 ft-lbs at -20°C
  - b.) Photocontrol shall pass an impact test after 1000 hours in a QUV chamber
    - Color shift shall not be more than one Pantone number after the QUV test
  - 5. Window shall be made of a UV stable and UV blocking acrylic polymer
  - 6. Photocontrol shall withstand a drop of three feet to a concrete floor without causing damage to the casing or changing electrical operation
- B. Housing Labeling
- 1. The year of manufacture shall be molded on the top of the photocontrol casing in a location that does not interfere with directional information
  - 2. Directional arrows marked “INSTALL” and “REMOVE” shall be molded on the top of the casing
  - 3. A directional arrow marked “NORTH” shall be molded on the top of the casing so an installed knows how to properly line up the photocontrol.
  - 4. The bottom of the photocontrol casing shall be stamped with month and year lists to enable installers to indicate an installation and removal date via pencil hash marks on the casing.
    - a.) This stamp shall consist of three concentric partial rings.
    - b.) The rings are broken by a small label box spanning all three rings.
    - c.) The outermost and innermost rings are blank by default.
    - d.) The center ring includes the numbers 1-12 to the left to indicate month and a list of 10 or more consecutive two digit years to the right.
    - e.) The label box shall indicate the outer ring is for installation information, the inner ring for removal information, the left side of the center ring is for the month, and the right side of the center ring is for the year. Abbreviations such as “mo” and “yr” are acceptable if space is limited.
- C. Base Label
- 1. The base label shall be affixed to the bottom of the photocontrol casing
  - 2. The base label shall not block or otherwise obscure other information on the casing
  - 3. The base label shall include the following information:
    - a.) Model number or model description
    - b.) The month and year of manufacture
    - c.) A unique serial number for the control
    - d.) Operating voltage range
    - e.) Load rating
    - f.) Manufacturing location
- D. Sensors
- 1. Photocontrols shall use a sealed silicon sensor. Cadmium sulfide cells are not acceptable.
  - 2. Sensor has a horizontal orientation and shall face the same direction as NORTH arrow and photocontrol window.
- E. Relays
- 1. Mechanical
    - a.) Relays shall be securely mounted to the printed circuit board
    - b.) Relays shall be fully sealed with a dust cover
  - 2. Relay Certification
    - a.) Relays shall be Underwriters Lab (UL) recognized.
  - 3. Relay Ratings
    - a.) Relays shall be SPST
    - b.) Relays shall be normally closed
    - c.) Relays shall be rated for a minimum of 16 Amps
    - d.) Relays shall be rated for a minimum of 1800 VA
    - e.) Relays shall be rated for a minimum of 1000 Watt tungsten
    - f.) Relays shall be rated for 5000 operations at full load
  - 4. Relay Response
    - a.) Relays shall have a make and break time of 5 milliseconds or less
- F. Surge Protection
- 1. Surge protection shall be in the form of a Metal Oxide Varistor (MOV) wired line to neutral
    - a.) MOV shall be rated for a minimum of 320 Joules (8x20 microseconds)
    - b.) MOV shall be rated for a minimum of 9500 Amp surge
    - c.) MOV shall have a continuous AC voltage of 320 VAC

- d.) MOV shall have a maximum clamp voltage of 850 Volts
  - e.) MOV shall have a peak current rating (with one pulse) of 9500 Amps
  - f.) MOV shall have an impulse response time of less than 50 nanoseconds
  - g.) MOV shall not fail when subjected to five surges of 9500 Amps applied at one minute intervals
  - h.) MOV shall be UL recognized under 1449
  - i.) MOV shall be RoHS certified
2. The photocontrols with MOV installed shall pass the following tests:
- a.) Photocontrol shall not fail when subjected to five surges of 9500 Amps applied at one minute intervals with 120 Volt AC applied
  - b.) Clamping voltage at measured at photocontrol legs shall not exceed 1050 Volts peak at 9500 Amps of surge
  - c.) Photocontrol shall meet all parts of IEEE standard C62.41.2-2002 including the tests outlined in the following table:

Exposure	Standard Tests		Optional Test
	1.2/50 microsecond Voltage generator	8/20 microsecond Current generator	100 kilohertz Ring Wave for front-of-wave response evaluation
	Minimum open circuit voltage to be applied to device	Current to be driven through device	
High	10 kilovolts	10 kiloamps	6 kilovolts

- d.) Photocontrol shall meet applicable clauses of the ANSI C136.2-2004 standard including the tests outlined in the following table:

Voltage Classification (rms)	60 Hertz dielectric withstand test		Transient voltage withstand test	
	1 minute dry (kilovolt-rms)	10 second wet (kilovolt-rms)	BIL full wave withstand test (kilovolt-peak)	Open circuit surge voltage (kilovolt-peak)
600	2.5	Not required	10	6

G. Legs and Gasket

- 1. All three legs shall be brass. Plated steel legs are not acceptable.
- 2. Gasket shall be neoprene or similar
- 3. Gasket must withstand a minimum 105 Celsius at 95% humidity

2.4 PACKAGING

- A. The photocontrols shall be sold in packages of 12 units
- B. Each photocontrol shall be individually packaged inside its own box
  - 1. Each individual box shall be 3.25 inches (82.6 millimeters) long, 3.25 inches (82.6 millimeters) wide, and 2.625 inches (66.7 millimeters) high
  - 2. Each individual box shall weigh 3.3 ounces (93 grams)
  - 3. Each individual box shall include installation instructions on one side
  - 4. Each individual box shall include warranty information on one side
  - 5. Each individual box shall include the location of control assembly
  - 6. Each individual box shall include a label with the following information
    - a.) The label shall include the model number
    - b.) The label shall include the voltage rating of the control

PART 3: EXECUTION

### 3.1 EQUIPMENT INSTALLATION AND DOCUMENTATION

- A. Installation - The photocontrol shall be installed and connected as directed by the manufacturer.
  - 1. The photocontrol is a locking type control and shall require no field wiring.
- B. Documentation - The complete product specification shall be available from the manufacturer.

### 3.2 PRODUCT SUPPORT AND SERVICE

Factory telephone support shall be available at no cost to the owner. Factory assistance shall consist of assistance in solving application issues pertaining to the control equipment.

### 3.3 WARRANTY

Manufacturer shall provide a six year (6) limited warranty on the photocontrol consisting of a one for one control replacement. The official warranty policy is the following:

All DTL photocontrols are permanently marked with month and year of manufacture as well as serial number.

DTL undertakes that this product shall operate within its original operating specifications and shall be free of electrical or mechanical defects. DTL's liability hereunder shall be limited to providing a replacement unit and shall not cover the costs of removal or installation of the unit nor any consequential damages.

This express warranty is in lieu of and excludes all other warranties, guaranties or representations, expressed or implied, including, but not limited to, warranties of merchantability or fitness for a specific purpose, by operation of law or otherwise.

END