

DTL DSW124 12A Control Specification Guideline  
Division 16520

PART 1. GENERAL

1.1 INTRODUCTION

- A. The intent of this specification is to provide for furnishing, installing, testing and placing into operation, a swivel type photocontrol for outdoor luminaires and junction boxes.

1.2 DESCRIPTION OF WORK

- A. Provide a swivel type photocontrol for outdoor lighting
- B. Requirements are indicated elsewhere in these specifications.
- C. Follow the following wiring diagram:

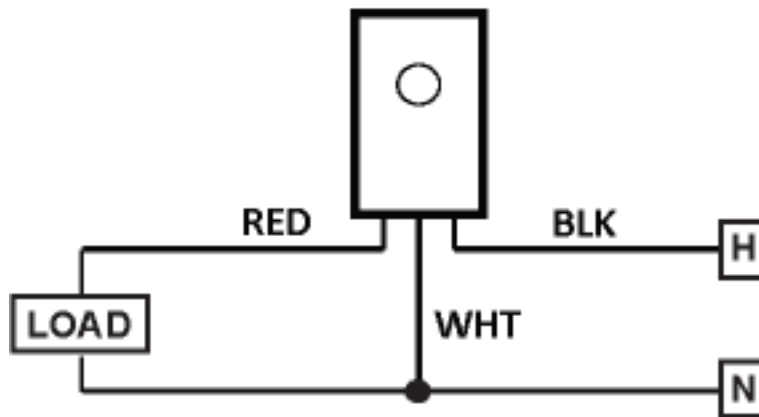

1.3 QUALITY ASSURANCE

- A. Independent Testing Laboratory - The controls shall be tested and listed under the UL 773A.
- B. Manufacturer experience - To insure a uniform installation and single responsibility, all switching equipment described herein shall be supplied by a manufacturer with a minimum of 10 years experience in lighting control systems.
- C. Manufacturer shall be:

Dark To Light  
3825 Columbus Rd. SW  
Granville, Oh. 43023  
800-442-6745  
www.darktlight.com

- D. Manufacturing Location shall be ISO certified.
- E. Product shall be DTL (Dark To Light) **DSW124 12A**. Alternate products meeting prior approval requirements may be proposed as add or deduct alternate only.

1.4 CODES AND STANDARDS

- A. UL 773A
- B. ANSI C136.10
- C. ANSI C136.24
- D. ANSI C136.2-2004
- E. IEEE C62.41.2-2002
- F. IES DG-13

## 1.5 SUBMITTALS

Prior to fabrication manufacture shall submit the following materials for approval.

- A. Manufacturer's published catalog data sheets for all equipment and components of the photocontrols.
- B. Shop Drawings - Submit detailed drawings and documentation of photocontrols. As a minimum, the shop drawings shall include the following:
  - 1. Schematic diagrams
  - 2. Full catalog sheets

## PART 2. PRODUCTS

### 2.1 SYSTEM DESCRIPTION

- A. The photocontrol shall control all luminaire on which it is installed.
- B. The photocontrol shall be a swivel type photocontrol as per ANSI C136.24
- C. The photocontrol shall operate at optimal levels when its window faces NORTH

### 2.2 RATINGS

- A. Photocontrol shall have a rated line voltage of 120-277 Volts AC at 50/60 Hertz
- B. Photocontrol shall have a load rating of at least 1000VA ballast.
- C. Photocontrol shall operate all HID, halogen, incandescent, LED, solid state, fluorescent, and relay loads
- D. Photocontrol shall consume 0.5 Watts or less at 120 Volts AC
- E. Photocontrol shall turn ON in  $1.5 \pm 0.5$  foot candles
- F. Photocontrol shall turn OFF at 1.5- 2 times the rate it turns ON.
- G. Photocontrol shall fail ON as per definitions in ANSI C136.24
- H. Photocontrol shall turn ON instantly
- I. Photocontrol shall have a 5-10 second delay before turning OFF
- J. Photocontrol shall operate in -40 degrees to 158 degrees Fahrenheit (-40 degrees to 70 degrees Celsius) temperatures

### 2.3 HARDWARE

- A. Housing, Nipple, Swivel, and Window
  - 1. The housing shall be 1.375 inches (34.9 millimeters) high, 3 inches (76.2 millimeters) long, and 2 inches (50.8 millimeters) wide
  - 2. The photocontrol shall weigh 3.4 ounces (96.4 grams)
  - 3. Housing of photoelectric control shall be gray flame-retardant polycarbonate
  - 4. Housing shall be made of an impact and UV resistant material.
    - a.) Photocontrol shall have an impact resistance of greater than 1.0 ft-lbs at -20°C
    - b.) Photocontrol shall pass an impact test after 1000 hours in a QUV chamber
      - Color shift shall not be more than one Pantone number after the QUV test.
  - 5. Nipple shall be threaded with half inch straight pipe thread that fits a standard half inch knock-out or threaded connector
  - 6. Nipple shall be 0.625 inches (15.875 millimeters) long
  - 7. Window shall be made of a UV stable and UV blocking polycarbonate that provides red and infrared filtering (all wavelengths over 900 nanometers)
  - 8. Swivel spans 180 degrees ranging from -30 to 150 degrees measured counterclockwise from the plane of the main control body
  - 9. Photocontrol shall withstand a drop of three feet to a concrete floor without causing damage to the casing or changing electrical operation.
  - 10. ½ in trade size galvanized steel lock nut shall be provided
- B. Mounting
  - 1. Photocontrol shall be mounted with the threaded nipple below the body of the control
- C. Front Label

1. The front label shall span the front of the control with a cutout for the window
  2. The label shall include the following information:
    - a.) Model number or model description
    - b.) Appropriate UL labeling
    - c.) Operating voltage range
    - d.) Load rating
    - e.) Complete wiring diagram
- D. Sensors
1. Photocontrols shall use a sealed silicon sensor. Cadmium sulfide cells are not acceptable.
- E. Relays
1. Mechanical
    - a.) Relays shall be securely mounted to the printed circuit board
    - b.) Relays shall be fully sealed with a dust cover
  2. Relay Certification
    - a.) Relays shall be Underwriters Lab (UL) recognized.
  3. Relay Ratings
    - a.) Relays shall be SPST
    - b.) Relays shall be normally closed
    - c.) Relays shall be rated for a minimum of 16 Amps
    - d.) Relays shall be rated for a minimum of 1800 VA
    - e.) Relays shall be rated for a minimum of 1000 Watt tungsten
    - f.) Relays shall be rated for 5000 operations at full load
  4. Relay Response
    - a.) Relays shall have a make and break time of 5 milliseconds or less
- F. Surge Protection
1. Surge protection shall be in the form of a Metal Oxide Varistor (MOV) wired line to neutral
    - a.) MOV shall be rated for a minimum of 190 Joules
    - b.) MOV shall be rated for a minimum of 6500 Amp surge
    - c.) MOV shall have a continuous AC voltage of 320 VAC
    - d.) MOV shall have a maximum clamp voltage of 850 Volts
    - e.) MOV shall have a peak current rating (with one pulse) of 6500 Amps
    - f.) MOV shall have an impulse response time of less than 50 nanoseconds
    - g.) MOV shall not fail when subjected to five surges of 6500 Amps applied at one minute intervals
    - h.) MOV shall be UL recognized under 1449, 3<sup>rd</sup> Edition
    - i.) MOV shall be RoHS certified
  2. The photocontrols with MOV installed shall pass the following tests:
    - a.) Photocontrol shall not fail when subjected to five surges of 4500 Amps applied at one minute intervals with 120 Volt AC applied
    - b.) Clamping voltage at measured at photocontrol leads shall not exceed 1050 Volts peak at 6500 Amps of surge
    - c.) Photocontrol shall meet all parts of IEEE standard C62.41.2-2002 including the tests outlined in the following table:

Exposure	Standard Tests		Optional Test  100 kilohertz Ring Wave for front-of-wave response evaluation
	1.2/50 microsecond Voltage generator	8/20 microsecond Current generator	
	Minimum open circuit voltage to be applied to device	Current to be driven through device	
High	10 kilovolts	10 kiloamps	6 kilovolts

- d.) Photocontrol shall meet applicable clauses of the ANSI C136.2-2004 standard including the tests outlined in the following table:

Voltage Classification RMS	60 Hertz dielectric withstand test		Transient voltage withstand test	
	1 minute dry KV-rms	10 second wet kilovolt-rms)	BIL full wave Withstand test (kilovolt-peak)	Open Circuit surge voltage (kilovolt-peak)
600	2.5	Not required	7.5	4.5

G. Leads

1. Photocontrol shall have three leads assigned as follows:
  - a.) Black = line
  - b.) Red = load
  - c.) White = neutral or common
2. Leads shall be a minimum of 12 inches (304.8 millimeters) long
3. Leads shall use #16 awg (American Wire Gauge)
4. Leads shall be rated for use up to 200 degrees Celsius

2.4 PACKAGING

- A. The photocontrols shall be sold in packages of 12 units
- B. Each photocontrol shall be individually packaged inside its own box
  1. Each individual box shall be 3 inches (63.5 millimeters) long, 2.25 inches (57.2 millimeters) wide, and 4.625 inches (117.5 millimeters) high
  2. Each individual box shall weigh 3.9 ounces (110.6 grams)
  3. Each individual box shall include installation and wiring instructions on one side
  4. Each individual box shall include warranty information on one side
  5. Each individual box shall include a label with the following information
    - a.) The label shall include the model number
    - b.) The label shall include the voltage rating of the control

PART 3: EXECUTION

3.1 EQUIPMENT INSTALLATION AND DOCUMENTATION

- A. Installation - The photocontrol shall be installed and connected as directed by the manufacturer. The official installation instructions follow:

Mount control so that the threaded nipple is below the main body of the control (the label faces upright in this position). The sensor window should be facing upward at an approximately 45 degrees (or more) angle from vertical and should be directed away from any lights, lighted areas, and reflective surfaces. Examples of objects to avoid include but are not limited to glass windows and walls, neon signs, street lights, black marble walls, and snow. For best results, the sensor window should also be directed away from tree canopies and other obstructions that might prevent natural light from reaching the sensor.

- B. Documentation - The complete product specification shall be available from the manufacturer.

3.2 PRODUCT SUPPORT AND SERVICE

Factory telephone support shall be available at no cost to the owner. Factory assistance shall consist of assistance in solving application issues pertaining to the control equipment.

3.3 WARRANTY

Manufacturer shall provide a six year (6) limited warranty on the photocontrol consisting of a one for one control replacement. The official warranty policy is the following:

All DTL photocontrols are permanently marked with month and year of manufacture as well as serial number.

DTL undertakes that this product shall operate within its original operating specifications and shall be free of electrical or mechanical defects. DTL's liability hereunder shall be limited to providing a replacement unit and shall not cover the costs of removal or installation of the unit nor any consequential damages.

This express warranty is in lieu of and excludes all other warranties, guaranties or representations, expressed or implied, including, but not limited to, warranties of merchantability or fitness for a specific purpose, by operation of law or otherwise.

END